

# DuraPRO®

Tools That Work For You®



**CORDLESS**

# HIGH-IMPACT DRIVER & WORK LIGHT



## OPERATOR'S MANUAL

SAVE THIS MANUAL FOR FUTURE REFERENCE



**WARNING:**

To reduce the risk of injury, the user must read and understand the operator's manual before using this product.

# TABLE OF CONTENTS

Symbols .....	3
General Safety Rules .....	2, 4
Specific Safety Rules .....	5, 7, 11
Features .....	8, 11
Assembly .....	9, 12
Operation .....	6, 10, 12
Maintenance .....	12

**DuraPRO**®

*Tools That Work For You*®



**WARRANTY:** DuraPRO® products are designed with quality in mind. This product is warranted against defects in material and workmanship for three years from the date of purchase. This warranty does not apply to defects or damage caused by misuse, alteration or normal wear and tear, and is limited only to replacement of this tool.



**WARNING:** To avoid serious personal injury, do not attempt to use this product until you read thoroughly and understand completely the operator's manual. Save this operator's manual and review frequently for continuing safe operation and instructing others who may use this product.



**WARNING:** The operation of any power tool can result in foreign objects being thrown into your eyes, which can result in severe eye damage. Before beginning power tool operation, always wear safety goggles or safety glasses with side shields and a full face shield when needed.



**WARNING:** Some dust created by power sanding, sawing, grinding, drilling, and other construction activities contains chemicals known to cause cancer, birth defects or other reproductive harm. Some examples of these chemicals are:

- lead from lead-based paints,
- crystalline silica from bricks and cement and other masonry products, and
- arsenic and chromium from chemically-treated lumber.



Your risk from these exposures varies, depending on how often you do this type of work. To reduce your exposure to these chemicals: work in a well ventilated area, and work with approved safety equipment, such as those dust masks that are specially designed to filter out microscopic particles.

**SERVICE** Servicing requires extreme care and knowledge and should be performed only by a qualified service technician. For service we suggest you return the product to your nearest **AUTHORIZED SERVICE CENTER** for repair. When servicing, use only identical replacement parts.



**Innovative Concepts Corporation**  
Torrington, CT 06790 U.S.A.

DuraPRO is a registered trademark of ICC Innovative Concepts Corporation

**Visit us at [www.durapro.com](http://www.durapro.com)**

Recyclable 

0106

**Customer Service**







860-482-0512  
9a-5p M-F, EST

**MADE IN CHINA**



Imported by  
Costco Wholesale Canada Ltd.\*  
415 W. Hunt Club Road  
Ottawa, Ontario, Canada  
K2E 1C5  
1-800-774-2678 (U.S.A.)  
1-800-463-3783 (Canada)

# SYMBOLS

**IMPORTANT:** Some of the following symbols may be used on your tool. Please study them and learn their meaning. Proper interpretation of these symbols will allow you to operate the tool better and safer.

SYMBOL	NAME	DESIGNATION/EXPLANATION
V	Volts	Voltage (potential)
A	Amperes	Current
Hz	Hertz Frequency	(Cycles per second)
W	Watt	Power
min	Minutes	Time
===	Direct current	Type or a characteristic of current
n <sub>0</sub>	No load speed	Rotational speed, at no load
.../min	Revolutions or reciprocation per minute	Revolutions, strokes, surface speed, orbits etc. per minute
0	Off position	Zero speed, zero torque...
→	Arrow	Action in the direction of arrow
	Read The Operator's Manual	To reduce the risk of injury, user must read and understand operator's manual before using this product
	Eye Protection	Always wear safety goggles or safety glasses with side shields and a full face shield when operating this product.
	Breathing protection	Wear respirator or proper breathing protection when using this product
	Safety Alert	Precautions that involve your safety
	Safety Alert	Risk of electric shock
	Ni-Cad RBRC seal	Designates Ni-Cad battery recycling program

The following signal words and meanings are intended to explain the levels of risk associated with this product.

SYMBOL	SIGNAL	MEANING
	<b>DANGER:</b>	Indicates an imminently hazardous situation, which, if not avoided, will result in death or serious injury.
	<b>WARNING:</b>	Indicates a potentially hazardous situation, which, if not avoided, could result in death or serious injury.
	<b>CAUTION:</b>	Indicates a potentially hazardous situation, which, if not avoided, may result in minor or moderate injury.
	<b>CAUTION:</b>	(Without Safety Alert Symbol) Indicates a situation that may result in property damage.



This symbol designates that this tool is listed by Underwriters Laboratories, and listed to Canadian Standards by Underwriters Laboratories.

**SAVE THESE INSTRUCTIONS.** Refer to them frequently and use them to instruct others who may use this tool. If you loan someone this tool, loan them these instructions also to prevent misuse of the product and possible injury.

# GENERAL SAFETY RULES — FOR ALL BATTERY OPERATED TOOLS



**WARNING:** Read and understand all instructions. Failure to follow all instructions listed below, may result in electric shock, fire and/or serious personal injury. **SAVE THESE INSTRUCTIONS**

## WORK AREA

**Keep your work area clean and well lit.** Cluttered benches and dark areas invite accidents.

**Do not operate power tools in explosive atmospheres, such as in the presence of flammable liquids, gases, or dust.** Power tools create sparks which may ignite the dust or fumes.

**Keep by-standers, children, and visitors away while operating a power tool.** Distractions can cause you to lose control.

## ELECTRICAL SAFETY

**A battery operated tool with integral batteries or a separate battery pack must be recharged only with the specified charger for the battery.** A charger that may be suitable for one type of battery may create a risk of fire when used with another battery.

**Use battery operated tool only with specifically designated battery pack.** Use of any other batteries may create a risk of fire.

### Use battery only with charger listed:

BATTERY PACK . . . . . BP-B18  
CHARGER . . . . . CU10B18

**Power tool plugs must match the outlet.** Never modify the plug in any way. Do not use any adapter plugs with earthed (grounded) power tools. Unmodified plugs and matching outlets will reduce risk of electric shock.

**Avoid body contact with earthed or grounded surfaces such as pipes, radiators, ranges and refrigerators.** There is an increased risk of electric shock if your body is earthed or grounded.

**Do not expose power tools to rain or wet conditions.** Water entering a power tool will increase the risk of electric shock.

**Do not abuse the cord.** Never use the cord for carrying, pulling or unplugging the power tool. Keep cord away from heat, oil, sharp edges or moving parts. Damaged or entangled cords increase the risk of electric shock.

## PERSONAL SAFETY

**Stay alert, watch what you are doing, and use common sense when operating a power tool.** Do not use tool while tired or under the influence of drugs, alcohol, or medication. A moment of inattention while operating power tools may result in serious personal injury.

**Dress properly.** Do not wear loose clothing or jewelry. Contain long hair. Keep your hair, clothing, and gloves away from moving parts. Loose clothes, jewelry, or long hair can be caught in moving parts.

**Avoid accidental starting.** Be sure switch is in the locked or off position before inserting battery pack. Carrying tools with your finger on the switch or inserting the battery pack into a tool with the switch on invites accidents.

**Remove adjusting keys or wrenches before turning the tool on.** A wrench or a key that is left attached to a rotating part of the tool may result in personal injury.

**Do not overreach.** Keep proper footing and balance at all times. Proper footing and balance enable better control of the tool in unexpected situations.

**Use safety equipment.** Always wear eye protection. Dust mask, non-skid safety shoes, hard hat, or hearing protection must be used for appropriate conditions.

## TOOL USE AND CARE

**Use clamps or other practical way to secure and support the workpiece to a stable platform.** Holding the work by hand or against your body is unstable and may lead to loss of control.

**Do not force tool.** Use the correct tool for your application. The correct tool will do the job better and safer at the rate for which it is designed.

**Do not use tool if switch does not turn it on or off.** A tool that cannot be controlled with the switch is dangerous and must be repaired.

**Disconnect battery pack from tool or place the switch in the locked or off position before making any adjustments, changing accessories, or storing the tool.** Such preventive safety measures reduce the risk of starting the tool accidentally.

**Store idle tools out of reach of children and other untrained persons.** Tools are dangerous in the hands of untrained users.

**When battery pack is not in use, keep it away from other metal objects like:** paper clips, coins, keys, nails, screws, or other small metal objects that can make a connection from one terminal to another. Shorting the battery terminals together may cause sparks, burns, or a fire.

**Maintain power tools with care.** Keep cutting tools sharp and clean. Properly maintained tools with sharp cutting edge are less likely to bind and are easier to control.

**Check for misalignment or binding of moving parts, breakage of parts, and any other condition that may affect the tool's operation.** If damaged, have the tool serviced before using. Many accidents are caused by poorly maintained tools.

**Use only accessories that are recommended by the manufacturer for your model.** Accessories that may be suitable for one tool may create a risk of injury when used on another tool.

**Keep the tool and its handle dry, clean and free from oil and grease.** Always use a clean cloth when cleaning. Never use brake fluids, gasoline, petroleum-based products, or any strong solvents to clean your tool. Following this rule will reduce the risk of loss of control and deterioration of the enclosure plastic.

## SERVICE

Tool service must be performed only by qualified repair personnel. Service or maintenance performed by unqualified personnel may result in a risk of injury.

When servicing a tool, use only identical replacement parts. Follow instructions in the Maintenance section of this manual. Use of unauthorized parts or failure to follow Maintenance Instructions may create a risk of shock or injury.

## BATTERY/CHARGER SAFETY



**WARNING:** Before using battery charger, read all instructions and cautionary markings on (1) battery charger, (2) battery pack, and (3) product using battery.

Use only the charger which accompanied your product or direct replacement as listed in the catalog or this manual. Do not substitute any other charger. Use only approved chargers with your product.

Do not operate charger with a damaged cord or plug, which could cause shorting and electric shock. If damaged, have the charger replaced by an authorized serviceman.

Do not operate charger if it has received a sharp blow, been dropped, or otherwise damaged in any way. Take it to an authorized serviceman for electrical check to determine if the charger is in good working order.

Do not disassemble charger. Take it to an authorized serviceman when service or repair is required. Incorrect reassembly may result in a risk of electric shock or fire.

Do not abuse cord or charger. Never use the cord to carry the charger. Do not pull the charger cord rather than the plug when disconnecting from receptacle. Damage to the cord or charger could occur and create an electric shock hazard. Replace damaged cords immediately.

Make sure cord is located so that it will not be stepped on, tripped over, come in contact with sharp edges or moving parts or otherwise subjected to damage or stress. This will reduce the risk of accidental falls, which could cause injury, and damage to the cord, which could result in electric shock.

Keep cord and charger from heat to prevent damage to housing or internal parts.

Do not let gasoline, oils, petroleum-based products, etc. come in contact with plastic parts. They contain chemicals that can damage, weaken, or destroy plastic.

An extension cord should not be used.

Do not recharge battery in damp or wet environment. Do not expose charger to rain or snow. If battery case is cracked or otherwise damaged, do not insert into charger. Water entering charger will increase the risk of electric shock.

Charge only approved rechargeable batteries. Other types of batteries may burst causing personal injury and damage.

Charge battery pack in temperatures above +40 degrees F (4 degrees C) and below +105 degrees F (41 degrees C). Store tool and battery pack in locations where temperatures will not exceed 120 degrees F (49 degrees C). This is important to prevent serious damage to the battery cells.

Battery leakage may occur under extreme usage or temperature conditions. Avoid contact with skin and eyes. The battery liquid is caustic and could cause chemical burns to tissues. If liquid comes in contact with skin, wash quickly with soap and water, then with lemon juice or vinegar. If the liquid contacts your eyes, flush them with water for a minimum of 10 minutes and seek medical attention.

Place charger on flat non-flammable surfaces and away from flammable materials when re-charging battery pack. The charger and battery pack heat during charging. Carpeting and other heat insulating surfaces block proper air circulation which may cause overheating of the charger and battery pack. If smoke or melting of the case are observed unplug the charger immediately and do not use the battery pack or charger. Use of an attachment not recommended or sold by DuraPRO® may result in a risk of fire, electric shock or injury to persons.

Unplug charger from outlet before attempting any maintenance or cleaning to reduce the risk of electric shock.

Disconnect charger from the power supply when not in use. This will reduce the risk of electric shock or damage to the charger if metal items should fall into the opening. It also will help prevent damage to the charger during a power surge.

Risk of electric shock. Do not touch uninsulated portion of output connector or uninsulated battery terminal.

When batteries are not in tool or charger, keep them away from metal objects. For example, to protect terminals from shorting DO NOT place batteries in a tool box or pocket with nails, screws, keys, etc. Fire or injury may result.

DO NOT PUT BATTERIES INTO FIRE OR EXPOSE TO HIGH HEAT. They may explode.

## BATTERY DISPOSAL



### NICKEL-CADMIUM BATTERIES

This product contains nickel-cadmium batteries. Local, state or federal laws may prohibit disposal of nickel-cadmium batteries in ordinary trash.



The EPA certified RBRC Battery Recycling Seal on the nickel-cadmium (Ni-Cd) battery indicates DuraPRO® is voluntarily participating in an industry program to collect and recycle these batteries at the end of their useful life, when taken out of service in the United States or Canada. The RBRC program provides a convenient alternative to placing used Ni-Cd batteries into the trash or the municipal waste stream, which may be illegal in your area.

Please call 1-800-8-BATTERY for information on Ni-Cd battery recycling and disposal bans/restrictions in your area.



**WARNING:** Upon removal, cover the battery pack's terminals with heavy-duty adhesive tape. Do not attempt to destroy or disassemble battery pack or remove any of its components. Nickel-cadmium batteries must be recycled or disposed of properly. Also, never touch both terminals with metal objects and/or body parts as short circuit may result. Keep away from children. Failure to comply with these warnings could result in fire and/or serious injury.

# OPERATION

## LED FUNCTIONS OF CHARGER

LED WILL BE ON TO INDICATE STATUS OF CHARGER AND BATTERY PACK:

**Red LED on** = Fast charging mode.

**Green LED on** = Fully charged and in maintenance charge mode.

**No LED on** = Defective charger or battery pack.

## CHARGING THE BATTERY PACK



**WARNING: A new battery pack is not charged and must be fully charged before first use. Never charge the battery pack again immediately after a fast charging process has been completed. This can cause the battery pack to become overcharged and may reduce the life of the battery and charger. Do not leave battery pack in charger over 3 hours after the green light turns on.**

**NOTE:** Batteries will not reach full charge the first time they are charged. Allow several cycles (operation followed by recharging) for them to become fully charged.

**NOTE:** If the charger does not charge the battery pack under normal circumstances, return both the battery pack and charger.

**Charge the battery pack only with a recommended charger. CU10B18**

- 1 Place the battery pack in the charger aligning raised rib on the battery pack with the groove in the charger.
- 2 Press down on the battery pack to be sure contacts on the battery pack engage properly with contacts in the charger.
- 3 Make sure the power supply is normal household voltage, 120 volts, 60 Hz, AC only.
- 4 Connect the charger to the power supply.

Normally the red LED on charger will come on. This indicates the charger is in fast charging mode.

**Red LED should remain on for approximately 1 hour then the green LED will come on.** Green LED on indicates battery pack is fully charged.

**NOTE:** The green LED will remain on until the battery pack is removed from the charger or charger is disconnected from the power supply.

After normal usage, a minimum of 1 hour of charging time is required to fully recharge battery pack.

The battery pack will become slightly warm to the touch while charging. This is normal and does not indicate a problem.

**Do not place the charger and battery pack in an area of extreme heat or cold.** They will work best at normal room temperature.

**NOTE:** The charger and battery pack should be placed in a location where the temperature is more than 50°F but less than 100°F.

**When batteries become fully charged, unplug the charger from power supply and remove the battery pack.**

**If you wish to charge a second battery pack, unplug charger from power supply.** Keep charger off for at least 15 minutes. Then you can start to charge the second battery. If you do not unplug charger before the second charging process starts, then the second battery cannot be charged.

**CAUTION:** To prevent damage to the battery pack, remove the battery pack from the charger immediately if no LED comes on. Return the battery pack and charger to your nearest service center for checking or replacing. Also, if you are removing the battery pack from the charger and no LEDs are on, return both the battery pack and the charger to your nearest service center. Do not insert another battery pack into the charger. A damaged charger may damage a battery pack.

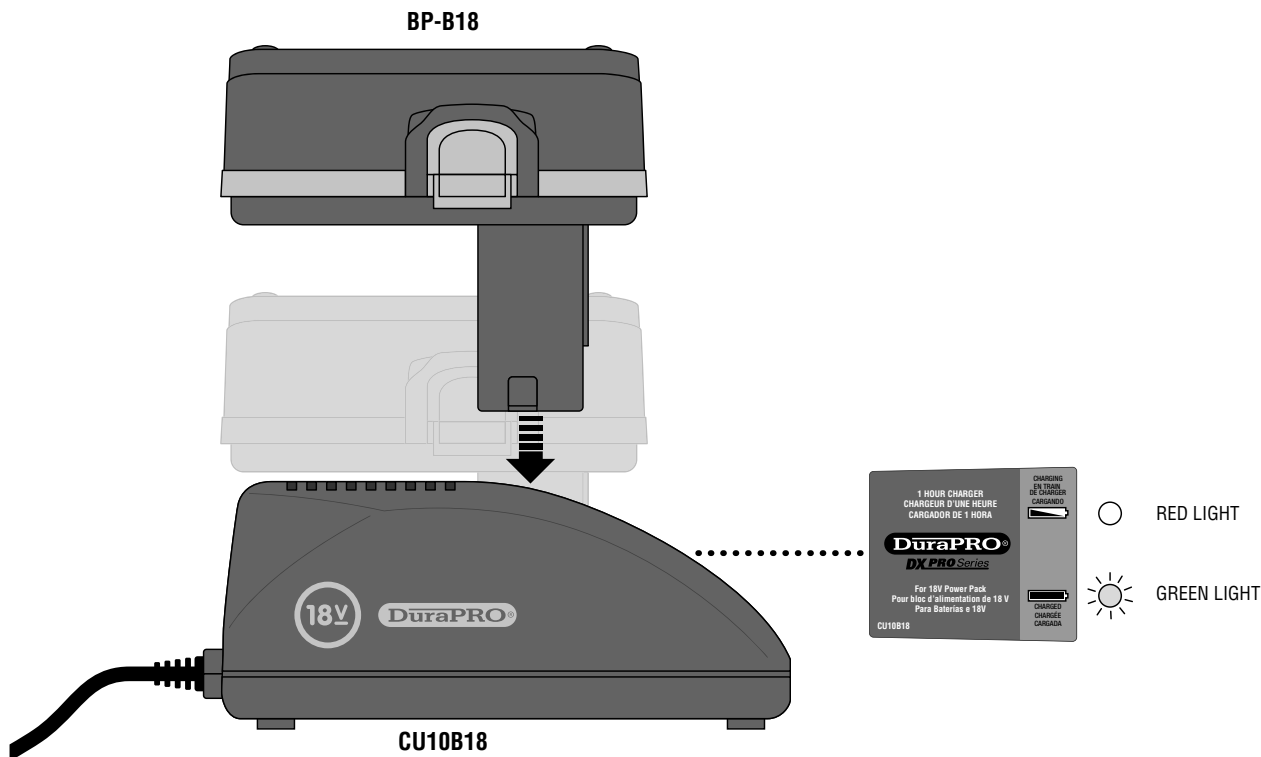

## SAFETY RULES FOR CORDLESS DRIVERS

**Know your power tool.** Read operator's manual carefully. Learn its applications and limitations, as well as the specific potential hazards related to this tool. Following this rule will reduce the risk of electric shock, fire, or serious injury.

**Always wear safety glasses with side shields.** Everyday glasses have only impact resistant lenses. They are NOT safety glasses. Following this rule will reduce the risk of eye injury.

**Protect your lungs.** Wear a face or dust mask if the operation is dusty. Following this rule will reduce the risk of serious personal injury.

**Protect your hearing.** Wear hearing protection during extended periods of operation. Following this rule will reduce the risk of serious personal injury.

**Use thick cushioned gloves and limit the exposure time by taking frequent rest periods.** Vibration caused by hammer-drill action may be harmful to your hands and arms.

**Hold tools by insulated gripping surfaces when performing an operation where the cutting tool may contact hidden wiring or its own cord.** Contact with a "live" wire will make exposed metal parts of the tool "live" and shock the operator. Do not drill, fasten or break into existing walls or other blind areas where electrical wiring may exist. If this situation is unavoidable, disconnect all fuses or circuit breakers feeding this work site.

**Secure the material being fastened.** Never hold it in your hand or across your legs. Unstable support can cause loss of control and injury.

**Battery tools do not have to be plugged into an electrical outlet; therefore, they are always in operating condition.** Be aware of possible hazards when not using your battery tool or when changing accessories. Following this rule will reduce the risk of electric shock, fire, or serious personal injury.

**Do not place battery tools or their batteries near fire or heat.** This will reduce the risk of explosion and possibly injury.

**Never use a battery that has been dropped or received a sharp blow.** A damaged battery is subject to explosion. Properly dispose of a dropped or damaged battery immediately.

**Batteries vent hydrogen gas and can explode in the presence of a source of ignition, such as a pilot light.** To reduce the risk of serious personal injury, never use any cordless product in the presence of open flame. An exploded battery can propel debris and chemicals. If exposed, flush with water immediately.

**Avoid accidental starting.** Be sure the forward/reverse switch is in the off position before inserting battery pack. Carrying appliances with your finger on the switch or inserting the battery pack into an appliance with the switch on invites accidents.

**Remove battery pack before changing accessories.** Accidental starting may occur because battery appliances with a battery inserted are in the operative condition.

**Be prepared for a reaction torque when "seating" or removing a fastener.** The screwdriver housing may tend to twist in the opposite direction of bit rotation when "seating" or removing a fastener depending on the torque setting of the tool.

**Do not use dull or damaged bits and accessories.** When installing an accessory, insert the shank of the bit well within the chuck. Be sure the chuck has locked onto the bit correctly.

**Do not run the tool while carrying it at your side.** A spinning bit could become entangled with clothing and injury may result.

**Place the tool onto the fastener only when the screwdriver is switched off.** Rotating driver tools can slide off the fastener.

**Be careful when driving long screws—there is a risk of sliding off the fastener head depending on type of socket or bit used.** First test the run-down of a fastener and pay attention during the screw driving process to insure you do not injure yourself if the tool bit or socket slides off of the fastener.

**Some dust created by power sanding, sawing, grinding, drilling and other construction activities contains chemicals known to cause cancer, birth defects or other reproductive harm.** Some examples of these chemicals are:

- Lead from lead-based paints
- Crystalline silica from bricks, cement and other masonry products.
- Arsenic and chromium from chemically treated lumber.

Your risk from these exposures varies depending on how often you do this type of work. To reduce your exposure to these chemicals, work in a well-ventilated area and work with approved safety equipment such as dust masks designed to filter out microscopic particles.

# FEATURES

## PRODUCT SPECIFICATIONS

Motor	18 Volt DC
Chuck	1/4"
Gear Train	One Speed
Switch	Variable Speed
No Load Speed	0-3,000/min.
Charger Input	120 V, 60 Hz, AC only
Charge Rate	1 Hour
Torque	Minimum 1,000 in.lb
Blows Per Minute	3,800/BPM

## KNOW YOUR IMPACT DRIVER

Before attempting to use this product, familiarize yourself with all operating features and safety rules.

### SWITCH LOCK

The switch trigger can be locked in the OFF position. This feature helps reduce the possibility of accidental starting when not in use.

### VARIABLE SPEED

This tool has a variable speed switch that delivers higher speed with increased trigger pressure. Speed is controlled by the amount of switch trigger depression.

### FORWARD/REVERSE SELECTOR (DIRECTION OF ROTATION SELECTOR)

The impact-driver has a forward/reverse selector located above the switch trigger.

### STORAGE

When not in use, remove bit from impact driver.

### BLOWS PER MINUTE

This tool features an impact speed of 3,800 Blows Per Minute (BPM). Blows Per Minute is the number of impacts per minute.

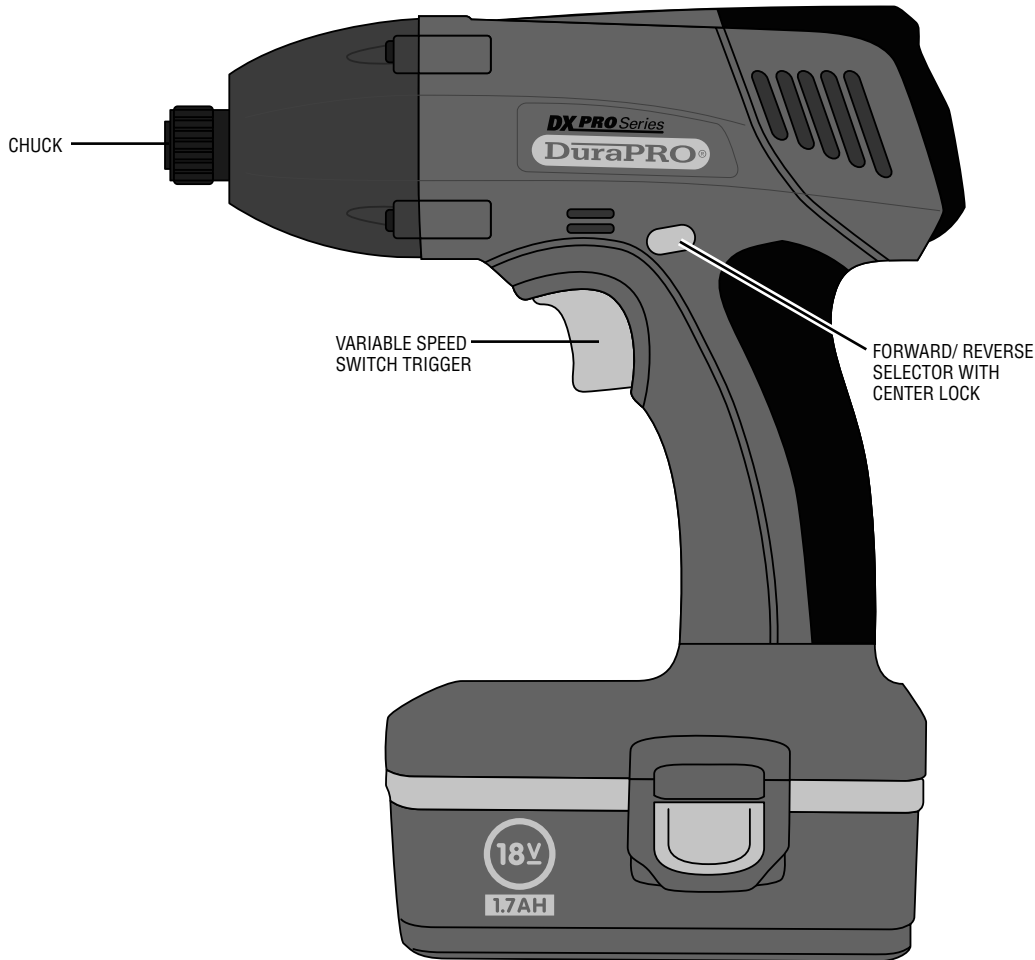

## ASSEMBLY

### UNPACKING

- This product has been shipped completely assembled.
- Carefully remove the tool and any accessories from the box. Make sure that all items listed in the packing list are included.
- Inspect the tool carefully to make sure no breakage or damage occurred during shipping.
- Do not discard the packing material until you have carefully inspected and satisfactorily operated the tool.



**WARNING:** If any parts are missing do not operate this tool until the missing parts are replaced. Failure to do so could result in possible serious personal injury.

**WARNING:** Do not attempt to modify this tool or create accessories not recommended for use with this tool. Any such alteration or modification is misuse and could result in a hazardous condition leading to possible serious personal injury.

**WARNING:** To prevent accidental starting that could cause serious personal injury, always remove the battery pack from the tool when assembling parts.

## OPERATION

### APPLICATIONS

You may use this tool for the following purposes:

- Driving long deck screws while building a deck
- Driving carriage bolts into deck posts
- Driving *Tapcon* screws into block walls and concrete
- Driving screws into metal studs



**WARNING:** Do not allow familiarity with tools to make you careless. Remember that a careless fraction of a second is sufficient to inflict serious injury.

**WARNING:** Always wear safety goggles or safety glasses with side shields when operating tools. Failure to do so could result in objects being thrown into your eyes, resulting in possible serious injury.

**WARNING:** Do not use any attachments or accessories not recommended by the manufacturer of this tool. The use of attachments or accessories not recommended can result in serious personal injury.

# OPERATION



**WARNING:** Battery tools are always in operating condition. Therefore, switch should always be locked when not in use or carrying at your side.

**CAUTION:** The metal surface may become hot during use. Avoid contact with it to avoid possible burn injury.

## SWITCH TRIGGER

To turn the tool ON, depress the switch trigger. To turn it OFF, release the switch trigger.

## SWITCH LOCK

The switch trigger can be locked in the OFF (center) position. This feature can be used to prevent the possibility of accidental starting when not in use. To lock switch trigger, place the direction of rotation selector in center position.

## REVERSIBLE

This tool has the feature of being reversible. The direction of rotation is controlled by a selector located above the switch trigger. With the tool held in normal operating position, the direction of rotation selector should be positioned to the left of the switch for tightening. The direction is reversed when the selector is to the right of the switch. When the selector is in center position, the switch trigger is locked.

## VARIABLE SPEED

This tool has a variable speed switch that delivers higher speed and torque with increased trigger pressure. Speed is controlled by the amount of switch trigger depression.

**CAUTION:** To prevent gear damage, always allow chuck to come to a complete stop before changing the direction of rotation. To stop, release switch trigger and allow the chuck to come to a complete stop.

## BUILT-IN CHUCK

The tool has a built-in chuck. The chuck has been designed to accept 1/4 in. hex bits.

## INSTALLING BITS

- 1 Lock switch trigger on the tool by placing the direction of rotation selector in center position.
- 2 Slide the chuck forward and hold in position.
- 3 Insert bit straight into chuck.
- 4 Slide the chuck back slowly and release.

## REMOVING BITS

- 1 Lock switch trigger on the drill by placing the direction of rotation selector in center position.
- 2 Slide the chuck forward and hold in position.
- 3 Pull bit straight out of chuck.

## TO INSTALL BATTERY PACK

- 1 Lock switch trigger on the tool by placing the direction of rotation selector in center position.
- 2 Place battery pack in the tool. Align raised rib inside tool with groove on battery pack.
- 3 Make sure the latches on each side of the battery pack snap into place and battery pack is secured in tool before beginning operation.

**CAUTION:** When placing battery pack in the tool, be sure raised rib inside tool aligns with groove on battery pack and latches snap in place properly. Improper assembly of battery pack can cause damage to internal components.

## TO REMOVE BATTERY PACK

- 1 Lock switch trigger on the tool by placing the direction of rotation selector in center position.
- 2 Locate latches on end of battery pack and depress to release battery pack from the tool.
- 3 Remove battery pack from the tool.

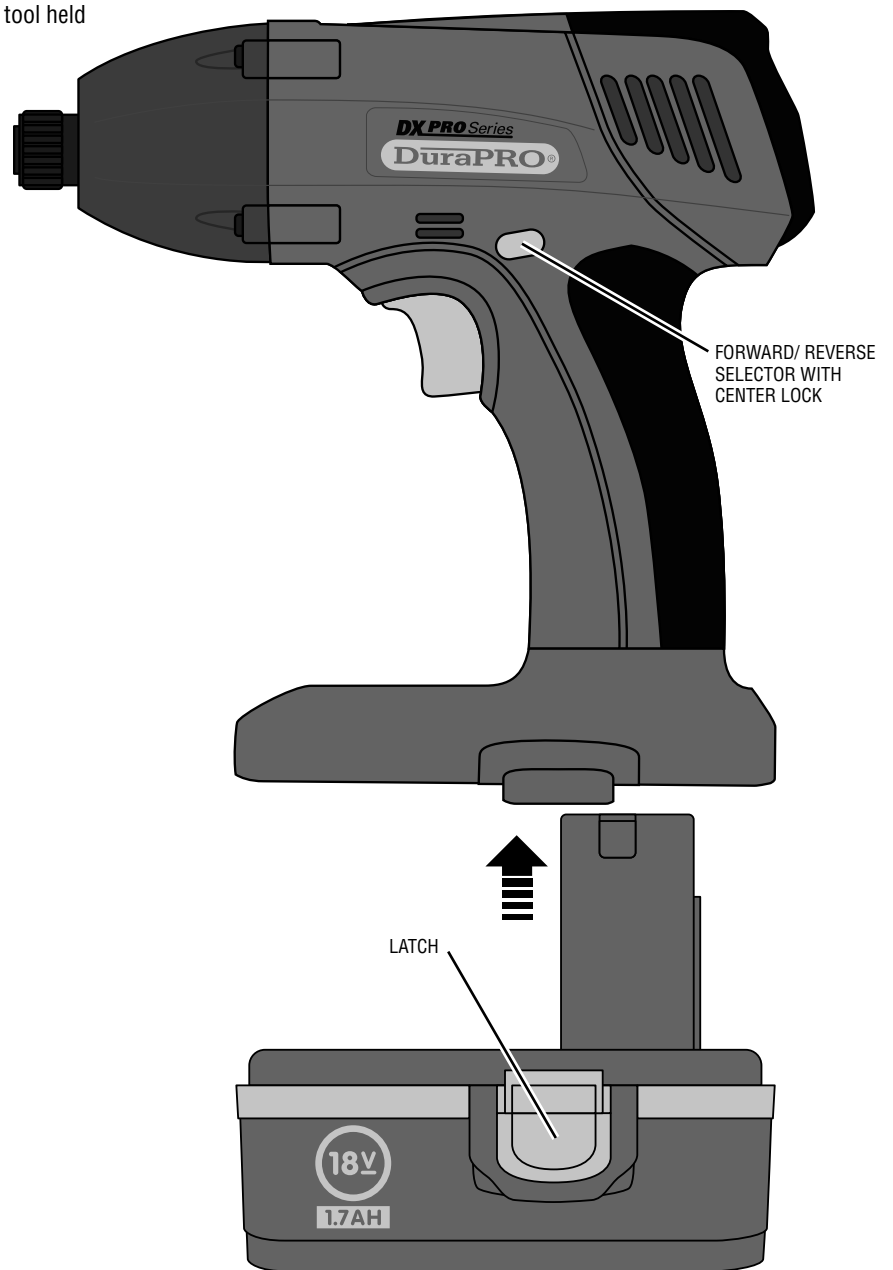

## SPECIFIC SAFETY RULES

**Know your work light.** Read operator's manual carefully. Learn its applications and limitations, as well as the specific potential hazards related to this work light. Following this rule will reduce the risk of electric shock, fire, or serious injury.

### Lens and bulb become hot during use:

- During or immediately after use, don't lay work light flat on lens surface or place lens area in contact with a plastic or fabric covered surface.
- Handle work light with care around any flammable surface.
- Let work light cool for several minutes after use before changing bulb.
- Do not use or permit use of work light in bed or sleeping bags. This work light lens can melt fabric and a burn injury could result.

**Use only the charger recommended for use with your work light.** Do not substitute any other charger. Use of another charger could cause batteries to explode causing possible serious injury.

**Use only recommended battery pack with your work light.** Any attempt to use another battery pack will cause damage to your work light and could possibly explode, cause a fire, or personal injury.

**Remove battery pack from work light before replacing bulb or performing any routine maintenance or cleaning.**

**Do not disassemble your work light.**

**Do not permit children to use work light unsupervised.** It is not a toy. The temperature of the bulb will become hot after being on for only a short period of time. This hot temperature can cause burn injury if touched and can create sufficient heat to melt some fabrics.

**If wrapped or in contact with fabrics, the work light lens can produce sufficient heat to melt some fabrics.** To avoid serious personal injury, never allow the work light lens to come in contact with anything.

**Check damaged parts.** Do not use work light if it does not function properly.

## FEATURES

### PRODUCT SPECIFICATIONS

Battery	18 Volt DC
Charger Input	120 V, 60 Hz, AC only
Charge Rate	1 hour
Bulb	KPR 18V 0.6A

### KNOW YOUR WORK LIGHT

Before attempting to use this product, familiarize yourself with all operating features and safety rules.

#### 180° ROTATING HEAD

Pivoting head rotates 180° allowing light to be projected in any direction.

### BULB REPLACEMENT

When purchasing replacement bulb, request recommended part number KPR 18V 0.6A.

### TO REPLACE BULB:

- 1 Allow bulb to cool.
- 2 Remove battery pack by depressing side latches to release from work light.
- 3 Remove lens cover by turning in a counterclockwise direction.
- 4 Remove old bulb from spring by pulling out.
- 5 Insert new bulb in spring and push in slightly to seat.
- 6 Replace lens cover.
- 7 Replace battery pack.

**NOTE:** For your convenience, the work light has a spare bulb storage area located behind the lens cover.

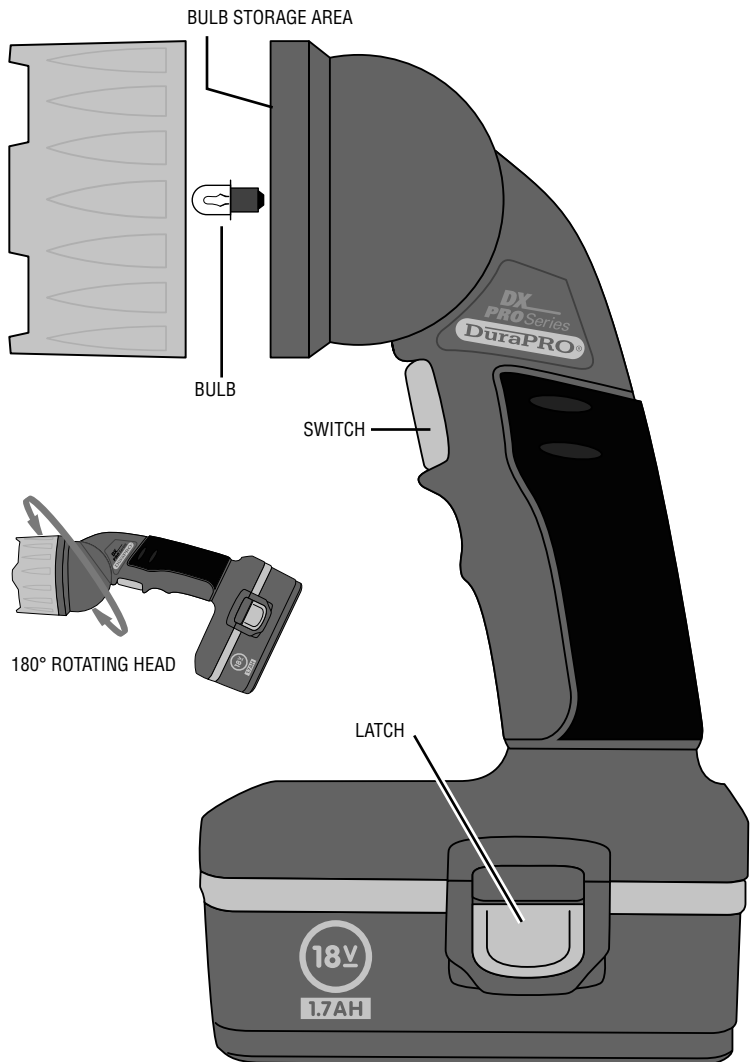

## ASSEMBLY

### UNPACKING

This product has been shipped completely assembled.

- Carefully remove the work light and any accessories from the box. Make sure that all items listed in the packing list are included.
- Inspect the work light carefully to make sure no breakage or damage occurred during shipping.
- Do not discard the packing material until you have carefully inspected and satisfactorily operated the work light.



**WARNING:** If any parts are missing do not operate this work light until the missing parts are replaced. Failure to do so could result in possible serious personal injury.

**WARNING:** Do not attempt to modify this work light or create accessories not recommended for use with this work light. Any such alteration or modification is misuse and could result in a hazardous condition leading to possible serious personal injury.

**WARNING:** Always remove the battery pack from the work light when assembling parts or changing light bulb. Failure to do so could result in possible serious personal injury.

## OPERATION

### SWITCH

To turn the work light ON and OFF, depress the switch.

### 180° ROTATING HEAD

Rotate the head of work light to change the direction of light beam.

**CAUTION:** Battery tools are always in operating condition. Use caution when carrying to prevent depressing the switch trigger when light is not needed.

## MAINTENANCE

### GENERAL MAINTENANCE

Avoid using solvents when cleaning plastic parts. Most plastics are susceptible to damage from various types of commercial solvents and may be damaged by their use. Use clean cloths to remove dirt, dust, oil, grease, etc.



**WARNING:** Do not at any time let brake fluids, gasoline, petroleum-based products, penetrating oils, etc., come in contact with plastic parts. Chemicals can damage, weaken or destroy plastic which may result in serious personal injury.



**WARNING:** When servicing, use only identical replacement parts. Use of any other parts may create a hazard or cause product damage.

**WARNING:** Always wear safety goggles or safety glasses with side shields when using compressed air to clean work lights. If operation is dusty, also wear a dust mask.

**WARNING:** To avoid serious personal injury, always remove the battery pack from the work light when cleaning or performing any maintenance.

